



FEATURES

- UNIVERSAL INPUT, 5 kHz, CAN POWER THE SENSOR
- NO NEED OF AMPLIFIERS OR LINEARIZERS
- SEVEN DIGIT RATE WITH PROGRAMMABLE DECIMAL PLACES
- THREE TOTALS UP TO 9 DIGIT, WITH PROGRAMMABLE DECIMAL PLACES. ONE NON-RESETTABLE, TWO RESETTABLE
- SHOWS VELOCITY OF THE LIQUID IN [m/s]
- SINGLE KFACTOR OR 10 POINT CALIBRATION CURVE
- KFACTORS FROM 0.00001 TO 9,999,999
- MILLILITERS, LITERS, GALLONS, CUBIC FEET, CUBIC METERS, ACRE FEET
- PER SECOND, PER MINUTE, PER HOUR, PER DAY
- ISOLATED 12 BIT ANALOG 4-20 mA PASSIVE OUTPUT
- ISOLATED NO POLARITY 100V/100mA DC/AC OUTPUT THAT CAN BE PROGRAMMED TO BE:
 - RATE ALARM, HIGH OR LOW
 - BATCH OUTPUT WITH A START INPUT
 - TOTAL LIMIT FOR 1 TO 64 DAYS WITH A RESUME INPUT
 - PULSE OUTPUT, UP TO 480 PULSES PER MINUTE (METERING PUMPS)
 - PULSE OUTPUT, UP TO 500 Hz
- PROGRAMMABLE FILTER (DAMPING)
- PROGRAMMABLE FLOW RATE CUT-OFF
- ALL SETTINGS STORED IN A NON-VOLATILE MEMORY
- SETTINGS LOCK/UNLOCK FOR SECURITY
- HIGH CONTRAST IN THE ENTIRE TEMPERATURE RANGE
- SIMPLE PROGRAMMING, SMALL SIZE

APPLICATIONS

- FLOW RATE AND TOTAL MEASUREMENT AND CONTROL
- BATCH APPLICATIONS
- LIMITING THE TOTAL IN ANY ROLLING PERIOD OF 1 TO 64 DAYS, PROGRAMMABLE
- METERING PUMPS PRECISE CONTROL FOR DOSING APPLICATIONS
- SCADA

1. DESCRIPTION

GFC111 is a low power flow computer / totalizer with an universal input and a variety of outputs. It provides power for many types of sensors and accepts their signal to measure flow rate and total. GFC111 has an isolated no polarity 100V/100mA DC/AC output that can be programmed to work as a rate alarm, high or low, with +/- 1 % hysteresis, batch, limit or pulse output. GFC111 also has an isolated 12 bit analog 4-20 mA passive output that can be connected to SCADA, PLC or another control device.

There is a screen that can be enabled to show velocity of the liquid in [m/s] for the particular diameter, entered.

For better accuracy GFC111 provides calibration curve capabilities for up to 10 points. In seconds the operator can switch between a single KFACTOR and the curve of up to 10 points.

A programmable filter (damping) helps having a stable flow rate reading.

A programmable flow rate cut-off can cut the reading when the liquid jitters.

GFC111 has a version in one inch wider enclosure – GFC111E.

The GFC111 software implements a version of our proprietary predictive/adaptive, self-adjusting digital filtering which provides extremely stable reading at any input frequency, plus very fast response to any change in the flow.

GFC111 is the perfect solution for flow measurement and control applications that require high accuracy and reliability, high isolation, multi-functionality, small size, industrial grade performance and low maintenance.



2. ABSOLUTE MAXIMUM RATINGS *

Operating temperature	-20 °C to +70 °C The electronics system is industrial (-40 °C to +85 °C) and higher grade . The Liquid Crystal Display (LCD) limits the temperature range.
Power supply voltage	40 VDC
Voltage for the analog output	40 VDC
Sensor consumption	20 mA DC
Digital output current	100 mA DC/AC. Alarm, batch, limit or pulse output
Digital output voltage	100 V DC, 70V AC. Alarm, batch, limit or pulse output

*** NOTE: Stresses above those ratings may cause permanent damage to the device.**

3. CHARACTERISTICS

Parameter	Conditions	Min	Typical	Max	Units
Power supply	-20 °C to +70 °C	12		36	V DC
Input					
Voltage for the sensor	-20 °C to +70 °C, max 20 mA, Note 1		10		V DC
Threshold, low	Wave or logical signal (CMOS, TTL etc.)		1.2		V DC
Threshold, high	Wave or logical signal (CMOS, TTL etc.)		1.6		V DC
Coil voltage	Symmetrical signal from the coil (sine, triangle, saw etc)	20			mVpp
NAMUR, low threshold	-20 °C to +70 °C, Powered by GFC111, Note 2		1		mA DC
NAMUR, high threshold	-20 °C to +70 °C, Powered by GFC111, Note 2		2.1		mA DC
Reed switch current	-20 °C to +70 °C, Powered by GFC111, Note 2			3.5	mA DC
Frequency	Note 7		5 000		Hz
Analog Output					
Power supply	-20 °C to +70 °C, Note 3	7.2		36	V DC
Resolution	-20 °C to +70 °C, 7.2 – 36 V		4		uA
Error	250 ohm load, 24 V, 25 °C, Note 4			0.05	% FS
Power supply error	7.2 - 36V, no load, output disabled, 25 °C			0.5	uA/V
Temperature coefficient	-20 °C to +70 °C, 24 V		35		ppm/°C
Current, output disabled	SET20 = 0.0, 24 V DC supply, 25 °C		3.85		mA
Digital Output					
Output ON resistance	-20 °C to +70 °C, 100 mA			8	ohm
Output OFF leakage	-20 °C to +70 °C, 100 V DC			5	nA
'Low', pulse rate	Note 5			480	p/min
'Low', pulse duration	Note 5		62.5		ms
'Low', pause duration	Note 5	62.5			ms
'High', pulse rate	Note 6			66000	p/min

Note 1: When powering a 3 wire sensor like open drain/collector pnp/npn sensor. For 2 wire sensors the current is automatically limited when powered by GFC111.

Note 2: If the 2 wire sensor uses external power, the external voltage must be 10 V DC or less.

Note 3: The minimum voltage for the 4-20 mA output to operate is $V = 7.2 + R_{load} [ohm] * 0.020$ [V DC]
For a GFC111 with a load of 250 ohm, the minimum voltage would be 12.2 V DC.

Note 4: The parameter includes all errors, non-linearity and noise at constant voltage and temperature.

Note 5: Pulse output has been programmed to be 'low' – low pulse rate for metering pumps applications. Pulse and pause widths are fixed.



Note 6: Pulse output has been programmed to be 'high' – high pulse rate for SCADA, PLCs etc. Pulse and pause have equal widths.

Note 7: The values are for reference only. The maximum frequency strongly depends on the duty cycle of the signal and the type of the sensor.

3.1. BUTTONS

There are three buttons: **SET** , **UP**  and **RIGHT**  :

- **SET** is used to enter and exit menus and confirm options chosen
 - **UP** is used to change the data
 - **RIGHT** is used to move the cursor (blinking digit or icon) to the right
- Additional button functions:

There are two types of buttons accepted by the GFC111 flow computer / totalizer:

- Short is when the button is pressed and released in less than 0.5 second
- Long is when it is kept pressed for more than 5 seconds
- All other durations are ignored

NOTE: The UP button will not change the value if the settings are locked.

3.2. INPUTS

GFC111 has two inputs:

- Pulse input from a flow sensor such as wave, logical signal, open drain/collector, npn/pnp, reed switches, dry contact, proximity/NAMUR sensors, Data Industrial 2 wire flow meters, turbine meters, coils and others. The computer / totalizer has all pull-up/down, current limiting and signal conditioning circuits built-in. The input also provides power for all types of sensors. There is no need to use external amplifiers for the coils if they provide more than 20 mVpp signal.
- Start/pause/resume input. This input is used for batch and limit applications with the output of GFC111 programmed as batch or limit. The intended use of this input is to connect to it a normal open push button, dry contact or an open drain sinking output. If the output of GFC111 is programmed as alarm or pulse, this input is ignored.

3.3. OUTPUTS

GFC111 has two isolated outputs:

3.3.1. Analog output

The isolated analog output is 4-20 mA, two wire, passive, 12 bit, with reverse polarity and surge protection, high accuracy and reliability. Using the **SET20** menu, it can be programmed to represent the flow rate.

SET20 parameter refers to the flow rate (in **volume rate units per time units**) the output will be 20 mA.

3.3.2. Digital output

The isolated digital output has no polarity, can work with 100V/100mA and can be programmed to be:



- Rate alarm, high or low, with +/- 1% hysteresis.
Example: If the alarm is programmed at 100.00 G/M and to be **high** the output will turn on when the flow rate exceeds 101.00 G/M and will turn off when it drops below 99.00 G/M. With **low** alarm the action will be reversed.
- Batch total
Example: The batch amount is programmed at 1000.0 G. The **total B** shows the batch amount accumulated and is not resettable. When **total B** reaches or exceeds 1000.0 G, the digital output turns OFF and **total B** stops increasing. Pressing the push button for more than 0.5 seconds will clear **total B**, turn the digital output ON and **total B** will start accumulating next batch amount. Pressing the push button before reaching 1000.0 G will pause the batch (**total B** not accumulating, output OFF). Pressing it again will resume the batch (output ON, **total B** accumulating).
- Limit total. This feature can limit the total for any rolling number of days programmed.
Example: To limit the total of water used to 500 gallons a week, program the limit to 500 gallons and the DAYS to 7. If the total in any rolling 7 days exceeds 500 gallons, the output will turn on and can shut the master valve off or perform another function. The output will stay on until the resume input (connected to a push button, switch etc.) is shorted. The total used is checked against the limit once a day, 24 hours after the previous check.
- Pulse output. This feature is intended for use with metering/dosing pumps, SCADA, PLCs and other devices.

The pulse output can be programmed for **low** or **high** pulse rate.

- When **low** it provides pulses with duration of 62.5 ms and pause longer than 62 ms. The output pulse rate is limited to about 480 pulses per minute for use with metering/dosing pumps.
- When the pulse output has been programmed for **high** rate it can provide up to 66,000 pulses per minute (1100 Hz) with equal duration of the pulse and the pause.

Example: You are adding chlorine or fertilizer to the water and have connected the control input of a pump to this pulse output. You program the “**SETP**” factor at 3.762 gallons per pulse. The pump will produce one pulse every 3.762 gallons and add the chlorine or the fertilizer in an exact proportion to the water.

3.4. DISPLAY

The liquid crystal display (LCD) has 7 digits with 5 decimal places and many icons. It shows rate, total, fluid velocity and all the variables and options that can be set or programmed. The rate and the totals have programmable auto, none, 1, 2, 3, 4 or 5 decimal places.

When the display shows rate, a “**RATE**” icon is displayed. If it shows total a “**TOTAL**” icon will be displayed along with “**A**”, “**B**” or “**C**” (GFC111 has three totals). If the screen for velocity is enabled there will be an icon “**FS**” (flow speed) and GFC111 will display the average fluid velocity for the particular diameter entered.

When input pulses are present, an “**INP**” (input) icon will be displayed.

When the digital output is ON an icon for cause will be displayed (**alarm, batch, limit or pulse**)

If the total on the LCD is allowed to be reset, a “**RESET**” icon will be displayed.



3.4.1. Volume and time units

- Milliliters (**mL**), liters (**L**), gallons (**G**), cubic feet (**CF**), cubic meters (**M³**) and acre feet (**AF**) per second (**S**), minute (**M**), hour (**H**) and day (**D**) are available.

3.4.2. Normal mode

Automatically after turning the power on or exiting a menu, GFC111 enters the normal mode.
Normal mode displays:

- Rate
- Total A, B or C. Total A reset can be enabled or disabled. It is stored in a non-volatile memory every 50 seconds or immediately when cleared.
Total B in batch mode for the output is non-resettable. It is the total that is compared against the pre-programmed batch volume.
If a total is allowed to be reset, the **RESET** icon is shown. Reset a total with long **RIGHT** button.
- Velocity of the fluid in [m/s] (meters per second) . This screen can be disabled.
- To switch between rate, total A, B, C or velocity use short **UP** button.

3.4.3. Menus

To enter the menus, use long **SET** button in normal mode. About 5 seconds after holding the **SET** button, the first menu will appear on the LCD:

- In the “total volume units” (**TOTAL vU**) menu, use **UP** to choose among **mL**, **L**, **G**, **CF**, **M³** and **AF**. Press short **SET** to move to next menu. While in this menu all the settings can be locked/unlocked. Use long **SET** then **UP** to lock/unlock the settings. Use short **SET** to go back to total volume units menu. If the settings are locked, they can be viewed, not changed. Press short **SET** for next menu.
- In the “rate volume units” (**RATE vU**) menu, use **UP** to choose among **mL**, **L**, **G**, **CF**, **M³** and **AF**. Press short **SET** to move to the “time unit menu.”
- In the “time unit” (**tU**) menu, use **UP** to choose the time units among **S**, **M**, **H** and **D**. Press short **SET** to move to the next menu.
- **SPEED** EN or DIS will enable or disable the 5th screen that shows the fluid velocity. Press short **SET**.
- If the velocity screen was enabled the next menu will be **diA**meter, where you have to enter the diameter in [mm] (millimeters) at which you want the velocity displayed. If you have the diameter **in inches multiply it by 25.4** . That must be an **internal** diameter of the pipe or the flow sensor orifice. Press short **SET** to continue. GFC111 will not accept zero for the diameter.

Make sure the pipe or the orifice is always full by proper mounting.

- **KFACTOR** icon along with a blinking decimal point and the KFACTOR number is shown. The decimal places for all KFACTORs (single KFACTOR and all KFACTORs in the calibration table) can be programmed using **UP** button. KFACTORs ranging from 0.00001 to 9,999,999 can be entered this way. To move from the blinking decimal point away and start entering the KFACTOR digits use the **RIGHT** button. The main **KFACTOR** for the particular flow meter connected to the GFC111 can be entered. This is how many **pulses** the flow computer will receive **per total volume unit**. From the **KFACTOR** menu use short **SET** to enter the next menu.



NOTE: the computer will not accept zero for the KFACTOR.

- In the CURvE menu, use short UP to change between blinking CURvE and blinking KFACTOR. The flow computer will use either the single KFACTOR or the calibration CURvE of up to 10 points for calculations. The points have to be entered before using the calibration curve. The factory default is 1.0 for the KFACTOR of each point. The curve is stored in a non-volatile memory, and the points can be entered in any order.
 - Enter the calibration data mode by using long **SET** in the **CURvE** menu for either a blinking **CURvE** or **KFACTOR**.
 - “**CAL Crv**” will appear on the LCD, and “**NO**” icon will be blinking. To continue choose **YES** and press short **SET**. To leave calibration curve data mode and leave the previous calibration data untouched, choose **NO** and press short **SET** to go back to the **CURvE** menu.

This feature is very useful for flow meters that have a calibration sheet provided by the manufacturer or the calibration laboratory. Each point consists of an input frequency in [Hz] and a KFACTOR (in **pulses per total volume units**) for that frequency.

Once you enter the calibration curve data menu, you have to go to the last point (point 9). If you have data for less points enter 0.0 for the frequency for all unused points. GFC111 will not accept 0.0 for any KFACTOR.

If **YES** has been chosen, “**Point 0**” will appear on the LCD. Press short **SET** and enter the input frequency in Hz for point 0. Press short **SET** and then enter the KFACTOR for that input frequency. Press short **SET** to do the same for the next point.

Repeat the above for up to 9 more points. After point 9, the flow computer will automatically return to the **CURvE** menu.

There is no need to enter the frequency at each point in a special (ascending/descending) order. The computer will automatically sort and validate the data and calculate all the parameters..

In the **CURvE** menu press short **SET** to move to **SET20** menu.

- In the **SET20** menu, set the flow rate (in **rate volume units per time unit**) at which you want the analog output to be 20.00 mA. Analog output will be 4.00 mA at 0.0 flow rate. If **SET20** = 0.0 the analog output will stay about 3.85 mA and will not change with the rate. Press short **SET** to move to the “**filter menu**.”
- In the **Filter** menu adjust the filtering (damping) allowing you to read a stable flow rate. Zero means an automatic filtering. One through seven are manual and the damping increases with the number. So does the response time. Press short **SET** to move to the “**Cut-off**” menu.
- In this menu enter the flow rate cut-off in **rate volume units per time unit**. Press short **SET** to move to the “**OUT Type**” menu.
- In the output type menu, use **UP** to choose the type of the output among **alarm**, **batch**, **limit** and **pulse**. Press short **SET** to move to the next menu.

* If alarm has just been chosen, the next menu will be the “**alarm type**” menu where using **UP** button **high** or **low** alarm can be chosen. Press short **SET** to move to the **alarm value** menu.



* If the **limit** output has been chosen, the next menu will be **DAYS** menu where the rolling number of days for the limit can be entered.

* If the **pulse** menu has been chosen the next menu will be **Pulse Type** (high/low). Use **low** pulse output for metering/dosing pumps with up to 480 strokes per minute. Use **high** pulse output to connect to a PLC, SCADA or other device that can accept up to 66 000 pulses per minute (1100 Hz). Use short **SET** to move to **SETP** menu.

- In the **output value** menu:
 - The value of the **alarm** must be in **rate volume units per time unit**
 - The value of the **batch** must be in **total volume units**, and it will compare to the **total B**
 - The value of the **limit** must be in **total volume units**
 - The value for **SETP** must be in **total volume units per pulse**

Note that the computer will not accept zero for those settings.
- If the **batch** function has been chosen pressing short **SET** will move to the “**overrun Compensation**” menu. Using it the extra liquid volume due to the valve closing delay can be compensated and the batch accuracy can be improved.
- Press short **SET** to move to the “**Rate decimal Places**” menu where (using short **UP**) auto, none, 1, 2, 3, 4 or 5 decimal places for the rate can be programmed.
- Press short **SET** to move to the “**Total decimal Places**” menu where (using short **UP**) auto, none, 1, 2, 3, 4 or 5 decimal places for all totals can be programmed.
If **AUTO** has been chosen GFC111 will use the icons “**x10**” and “**x100**”. When the total reaches 9 999 999 it will not clear but the icon **x10** will be used. When it reaches again 9 999 999, it will not clear but the icon **x100** will be used. This way the total extends to 9 digits and will clear after it reaches 999 999 999 (one billion).
- Press short **SET** to move to the **Total A Reset enable/disable** menu. In this menu using **UP** button the total A reset can be enabled or disabled.
If enabled and GFC111 is in normal mode displaying total A, the **RESET** icon will also be displayed and long **RIGHT** will clear total A.

Because this is the last menu, pressing long **SET** will move the computer to the **LOCK** menu. Use **UP** to lock the settings and press short **SET** to go back to **Total A Reset enable** menu. General practice would be to unlock the settings at the first menu. Settings can be changed and locked again before exiting at the last menu. Press short **SET** to exit. After a couple of seconds during which all the settings are checked, validated and stored into the non-volatile memory, the computer will return to the normal mode.

NOTE: The software time out feature will reset the computer and force it to the normal mode WITHOUT saving any changes made in any of the menus. The changes will only be saved after exiting the Total A Reset enable menu by pressing short SET.

NOTE: Even in menu mode, the computer always continues to measure and calculate rate and total and control the output so no total will be lost. In some circumstances, such as changing the KFACTOR, the total accumulated will be invalidated. The user must take appropriate actions after changing the settings, such as resetting the total for an instance.



3.5. Checking the LCD

All the icons of the LCD can be checked by pressing and holding the **RIGHT** button while powering on or after exiting the last menu. Releasing the button will return the computer to normal mode.

3.6. Removing the power

Total A is stored in the non-volatile memory every 50 seconds.

Before removing the power make sure that there was no flow for the last minute.

4. MENU DIAGRAM

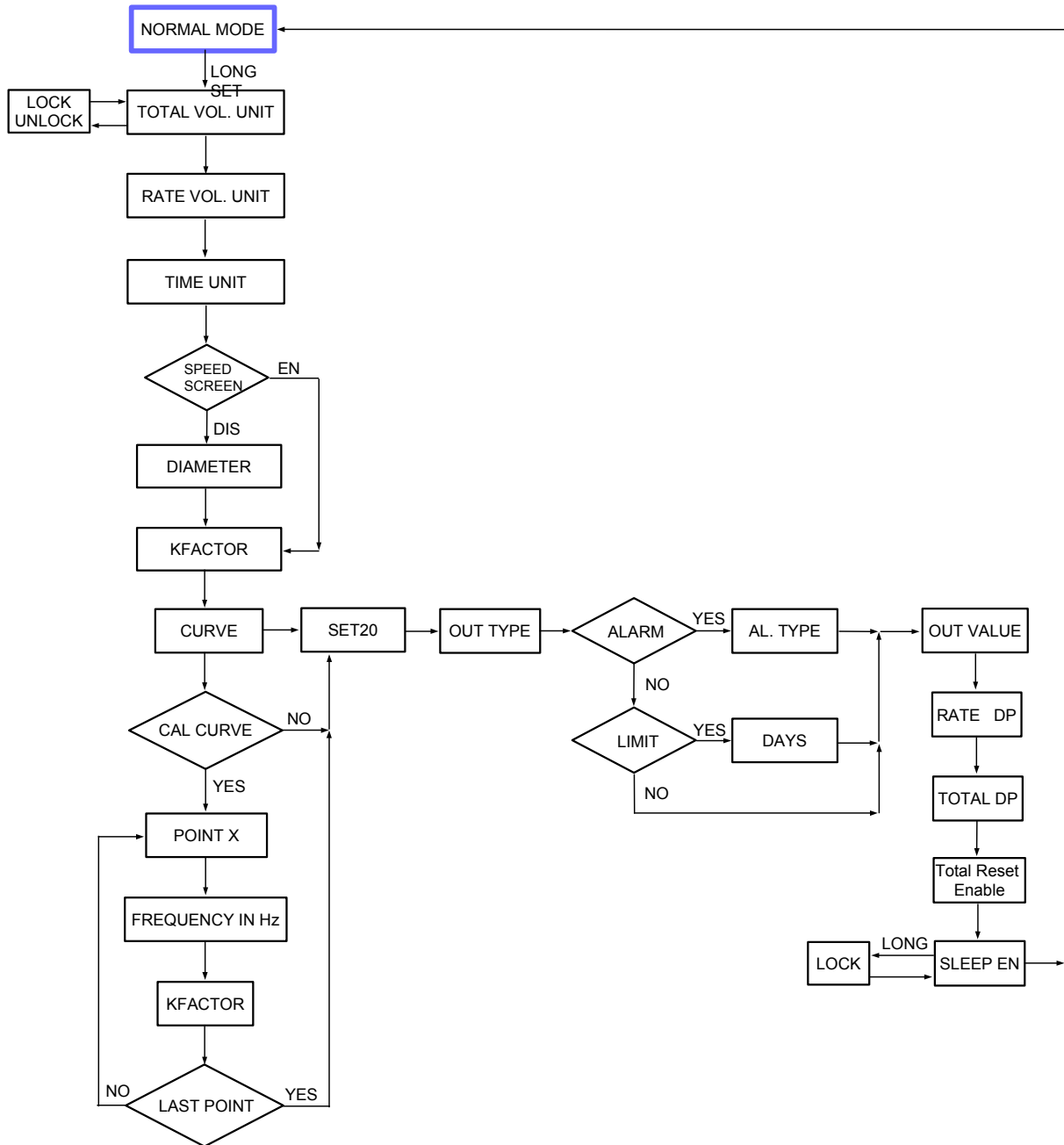

5. APPLICATION

5.1. ELECTRICAL

NOTE: There is no isolation between the sensor input, the power supply and the push button input.

5.1.1. Wiring the sensor

GFC111 accepts a variety of sensors. See below for wiring specifications and their particular wiring is shown below:

5.1.1.1. NPN Open Drain, Open Collector

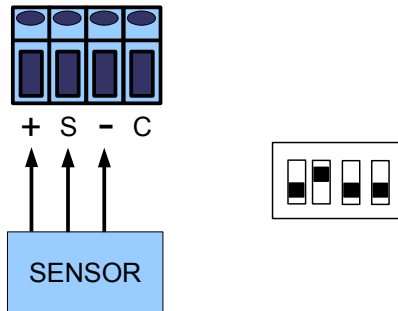

5.1.1.2. PNP Open Drain, Open Collector

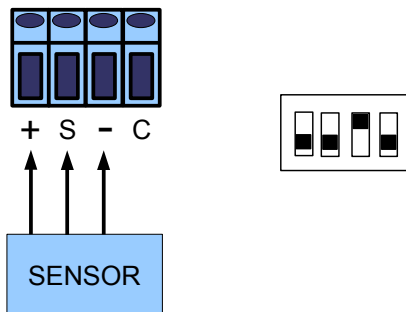

5.1.1.3. Reed Switch, Dry Contact

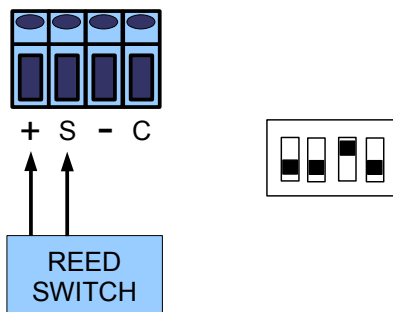

NOTE: Different reed switches and dry contacts have different bouncing time. Test and evaluate carefully to determine the right DIP switch setting.

5.1.1.4. Wave (square, sine, triangle, saw etc.), Logical Signal (CMOS, TTL etc.)

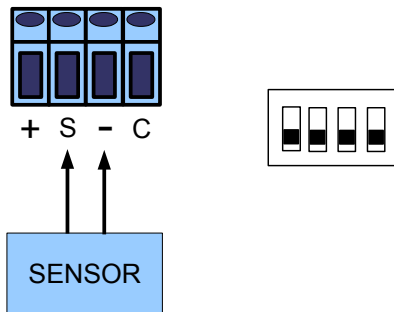

5.1.1.5. NAMUR Sensors, Data Industrial Two Wire Flow Meters

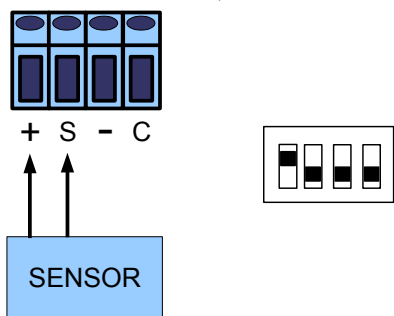

5.1.1.6. Coils

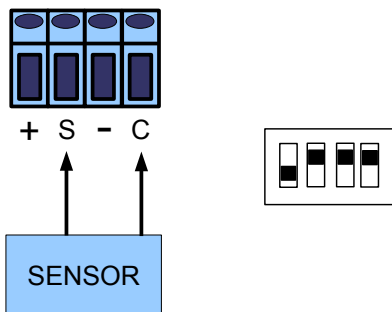

NOTE: If the cable to the coil is shielded, connect the shield to “-” (terminal 5) ONLY. Do not connect the shield to anything at the other (coil) end of the cable. The shield has to be isolated from earth ground and all other equipment or electrical connections.

5.2. VERSIONS



WALL MOUNT GFC111



WALL MOUNT GFC111E

6. ORDERING

For ordering please use the following G Instruments part numbers:

<i>Description</i>	<i>G Instruments PN</i>
GFC111 flow computer, no power supply (external isolated 12 – 36 V DC needed)	30401
GFC111 flow computer with GPS115 (115 VAC power supply)	30402
GFC111 flow computer with GPS220 (220 VAC power supply)	30403
GFC111 flow computer with GPS122 (85-264 VAC power supply)	30229
GFC111E flow computer, no power supply (external isolated 12 – 36 V DC needed)	30325
GFC111E flow computer with GPS115E (115 VAC power supply)	30326
GFC111E flow computer with GPS220E (220 VAC power supply)	30327
GFC111E flow computer with GPS122E (85-264 VAC power supply)	30328



IMPORTANT NOTICE

G Instruments reserves the right to make corrections, modifications, enhancements, improvements and other changes to its products at any time without notice.

Customers should obtain the latest relevant information before placing orders and should verify that such information is current and complete.

G Instruments does not assume any liability arising from the use of any device or circuit described herein, nor does it convey any license under its patent rights or the rights of others.

Customers are responsible for their products and applications using G Instruments devices. To minimize the risks associated with customer products and applications, customers should provide adequate design and operating safeguards.

G Instruments products are not authorized for use as critical components in life support devices or systems without express written approval of G Instruments.

Trademarks and registered trademarks are the property of their respective owners.