



FEATURES

- POWERS A BIDIRECTIONAL FLOW SENSOR
- MEASURES AND SHOWS FLOW RATE A OR FLOW RATE B
- MEASURES AND SHOWS TOTAL A, TOTAL B AND TOTAL A-B. ALL ARE x1000 Gallons
- SEVEN DIGIT RATE WITH PROGRAMMABLE DECIMAL PLACES
- KFACTORS FROM 0.001 TO 9,999.999
- MILLILITERS, LITERS, GALLONS, CUBIC FEET, CUBIC METERS, ACRE FEET
- PER SECOND, PER MINUTE, PER HOUR, PER DAY
- ISOLATED 12 BIT ANALOG 4-20 mA PASSIVE OUTPUT
- ISOLATED NO POLARITY 100V/100mA DC/AC ALARM OR PULSE OUTPUT FOR UP TO 500 Hz
- ALL SETTINGS STORED IN A NON-VOLATILE MEMORY
- SETTINGS LOCK/UNLOCK FOR SECURITY
- HIGH CONTRAST IN THE ENTIRE TEMPERATURE RANGE
- SIMPLE PROGRAMMING, SMALL SIZE

APPLICATIONS

- FLOW RATE AND TOTAL MEASUREMENT AND CONTROL
- FUEL USAGE MEASURING
- METERING PUMPS PRECISE CONTROL FOR DOSING APPLICATIONS
- SCADA



1. DESCRIPTION

GFC110A-B is a low power flow computer / totalizer that provides power to a bidirectional flow sensor, accepts its pulses, measures flow rate in either direction and accumulates the totals in both directions. It also calculates and displays total C = total A – total B. All totals are in thousands of gallons. If total B > total A the software will keep total C = 0.0.

GFC110A-B has an isolated no polarity 100V/100mA DC/AC digital output that can be programmed to work as a rate alarm, high or low, with +/- 1 % hysteresis or pulse output for up to 500 Hz. GFC110A-B also has an isolated 12 bit analog 4-20 mA passive output that can be connected to SCADA, PLC or another control device.

The software will not allow the total to go negative.

The software of GFC110A-B implements a version of our proprietary predictive/adaptive self-adjusting digital filtering which provides extremely stable reading at any input frequency and still very fast response to any change in the flow.

GFC110A-B is the perfect solution for flow measurement and control applications that require high accuracy and reliability, high isolation, multi-functionality, small size, industrial grade performance and long time without service.



2. ABSOLUTE MAXIMUM RATINGS *

Operating temperature	-20 °C to +70 °C The electronics is industrial (-40 °C to +85 °C) and higher grade . The Liquid Crystal Display (LCD) is limiting the temperature range.
Power supply voltage	40 VDC
Voltage for the analog output	40 VDC
Digital output current	100 mA DC/AC. Alarm, batch, limit or pulse output
Digital output voltage	100 V DC, 70V AC. Alarm, batch, limit or pulse output

*** NOTE: Stresses above those ratings may cause permanent damage to the device.**

3. CHARACTERISTICS

Parameter	Conditions	Min	Typical	Max	Units
Power supply voltage	-20 °C to +70 °C	8		36	V DC
Pulse Inputs					
Input frequency		0		800	Hz
Voltage for the sensor			5		V DC
High threshold		4			V DC
Low threshold				1	V DC
Analog Output					
Power Supply	-20 °C to +70 °C, Note 1	9.5		36	V DC
Resolution	-20 °C to +70 °C, 9.5 – 36 V DC		4		uA
Error	250 ohm load, 24 V, 25 °C, Note 2			0.05	% FS
Power supply error	9.5-36V, no load, output disabled, 25 °C			0.5	uA/V
Temperature coefficient	-20 °C to +70 °C, 24 V		35		ppm/°C
Current, output disabled	SET20 = 0.0, 24 V DC supply, 25 °C		3.85		mA
Digital Output					
Output ON resistance	-20 °C to +70 °C, 100 mA			8	ohm
Output OFF leakage	-20 °C to +70 °C, 100 V DC			5	nA
Pulse rate	500 Hz, Note 3	30000			p/min

Note 1: The minimum voltage for the 4-20 mA output to operate is $V = 9.5 + R \text{ load [ohm]} * 0.020$ [V DC]
For GFC110A-B with a load of 250 ohm connected the minimum voltage would be 14.5 V DC.

Note 2: The parameter includes all errors except temperature error

Note 3: Pulse and pause have equal widths.

3.1. BUTTONS

There are three buttons: **SET** , **UP**  and **RIGHT**  :

- **SET** is used to enter and exit menus and confirm options chosen
 - **UP** is used to change the data
 - **RIGHT** is used to move the cursor (blinking digit or icon) to the right
- The buttons have some other special functions that are mentioned below.



There are two types of buttons accepted by the GFC110A-B flow computer / totalizer:

- Short is when the button is pressed and released in less than 0.5 second
- Long is when it is kept pressed for more than 5 seconds
- All other durations are ignored

NOTE: The UP button will not change the value if the settings are locked.

3.2. INPUTS

GFC110A-B has two pulse inputs: pulses for direction A and pulses for direction B. The pulses can be provided by two separate flow sensors or a bidirectional flow sensor. The pulses from direction A will be added to total A, while the pulses for direction B will be added to total B. The resultant

total C = total A - total B can never become negative.

All three totals are in thousands of gallons (x1000).

3.3. OUTPUTS

GFC110A-B has two isolated outputs:

3.3.1. Analog output

The isolated analog output is 4-20 mA, two wire, passive, 12 bit, with reverse polarity and surge protection, high accuracy and reliability. Using the **SET20** menu it can be programmed to represent the flow rate.

SET20 parameter means at what **flow rate A** (in GPM) the output will be 20.00 mA.

3.3.2. Digital output

The isolated digital output has no polarity, can work with 100V/100mA and can be programmed to be:

- Rate alarm, high or low, with +/- 1% hysteresis.
Example: If the alarm is programmed at 100.00 GPM and to be **high** the output will turn on when **flow rate A** exceeds 101.00 GPM and will turn off when it drops below 99.00 GPM
With **low** alarm the action will be reversed.
- Pulse output. This feature is intended for use with metering/dosing pumps, SCADA, PLCs and other devices. It can provide up to 30 000 pulses per minute (500 Hz) with equal duration of the pulse and the pause.

Example: You are adding chlorine or fertilizer to the water and have connected the control input of a pump to this pulse output. You program the "**SETP**" factor at 3.76 Gallons per pulse. The pump will produce one pulse every 3.76 gallons **in direction A** and add the chlorine or the fertilizer in an exact proportion to the water.

3.4. DISPLAY

The liquid crystal display (LCD) has 7 digits with 1, 2 or 3 decimal places and many icons. It shows rate, total and all the variables and options that can be set or programmed. The rate and all totals have programmable auto, none, 1, 2 or 3 decimal places.



A “**FLOW**” icon will always be displayed.

When the display shows rate a “**RATE**” icon is displayed along with “**A**” or “**B**”. When it shows total a “**TOTAL**” icon will be displayed along with “**A**”, “**B**” or “**C**”.

When input pulses are present an “**INP**” (input) icon will be displayed.

Whenever the digital output is ON an icon for the cause will be displayed (**alarm** or **pulse**)

If the total on the LCD is allowed to be reset a “**RESET**” icon will be displayed.

3.4.1. Volume and time units

- Milliliters (**mL**), liters (**L**), gallons (**G**), cubic feet (**CF**), cubic meters (**M³**) and acre feet (**AF**) per second (**S**), minute (**M**), hour (**H**) and day (**D**) are available.

3.4.2. Normal mode

Automatically after turning the power on or exiting a menu GFC110A-B enters the normal mode.

In this mode it can only display:

- Rate A or Rate B
- Total A, total B and total C = total A – total B. Both total A and total B can be reset. Their reset can be enabled or disabled. Both totals are also stored in a non-volatile memory every 50 seconds or immediately when cleared.
If a total is allowed to be reset the **RESET** icon is shown. Resetting the total is by using long **RIGHT** button.
- Switching between rate A, rate B, total A, total B and total C is by using short **UP** button.

3.4.3. Menus

To enter the menus use long **SET** button in normal mode. About 5 seconds after pressing (and holding pressed) the **SET** button the first menu will appear on the LCD:

- **KFACTOR** icon is shown and using **UP** and **RIGHT** the **KFACTOR** for the particular flow meter connected to GFC110A-B can be entered. This is how many pulses the flow computer will receive from the flow meter for one gallon.
While in this menu all the settings can be locked/unlocked. Use **RIGHT** button to move the cursor to the right most digit and then use long **SET**.
 - Using short **UP** lock/unlock the settings. Then use short **SET** to go back to **KFACTOR** menu
 - If the settings are locked then they can only be viewed but not changed.

From the **KFACTOR** menu use short **SET** to enter the next menu. Note that the computer will not accept zero for the **KFACTOR**.

- In the **SET20** menu program the flow rate A (in GPM) at which you want the analog output to be 20.00 mA. The analog output will be 4.00 mA at 0.0 GPM. If **SET20** = 0 the analog output will stay about 3.85 mA and will not change with flow rate A. Press short **SET** to move to the “**volume units menu**”



- In the “volume units” (vU) menu use **UP** to choose the volume units among **mL, L, G, CF, M³** and **AF**. Press short **SET** to move to the “time unit menu”
- In the “time unit” (tU) menu use **UP** to choose the time unit among **S, M, H** and **D**. Press short **SET** to move to the “OUT Type” menu.
- In the output type menu use **UP** to choose the type of the digital output between **alarm** and **pulse**. Press short **SET** to move to the next menu.
 - * If **alarm** has just been chosen the next menu will be the “alarm type” menu where using **UP** button **high** or **low** alarm can be chosen. Press short **SET** to move to the **alarm value** menu.
 - * If the **pulse** menu has been chosen the next menu will be **SETP**.
- In the **output value** menu:
 - The value for the **alarm** must be in **GPM**
 - The value for **SETP** must be in **GALLONS PER PULSE**

Note that the computer will not accept zero for those settings.

- Press short **SET** to move to the “Rate decimal Places” menu where using short **UP** auto, none, 1, 2, or 3 decimal places for the flow rate can be programmed.
- Press short **SET** to move to the “Total decimal Places” menu where using short **UP** auto, none, 1, 2, or 3 decimal places for the total can be programmed.
- Press short **SET** to move to the **Total A Reset enable/disable** menu. In this menu using **UP** button the total reset of total A can be enabled or disabled.
If enabled and GFC110A-B is in normal mode displaying total A the **RESET** icon will also be displayed and long **RIGHT** will clear total A.
- Press short **SET** to move to the **Total B Reset enable/disable** menu. In this menu using **UP** button the total reset of total B can be enabled or disabled.
If enabled and GFC110A-B is in normal mode displaying total B the **RESET** icon will also be displayed and long **RIGHT** will clear total B.

Because this menu is the last one pressing a long **SET** will move the computer to the **LOCK** menu. Use **UP** to lock the settings and press short **SET** to go back to **Total B Reset enable** menu. General practice would be the settings to be unlocked at the first (**KFACTOR**) menu, then changed and locked again before exiting at the last menu. Press short **SET** to exit the last menu. After a couple of seconds during which all the settings are being checked, validated and stored into the non-volatile memory, the computer will move to the normal mode.

NOTE: There is a time out built-in the software that will reset the computer and force it to the normal mode WITHOUT saving any changes made in any of the menus. The changes will only be saved after exiting the Total B Reset enable menu by pressing short SET.

NOTE: During menus the computer continues to measure and calculate rate and total and control the output so no total will be lost. But changing for an instance the KFACTOR will invalidate the totals accumulated. So it would be the user's responsibility to take appropriate actions after changing the settings like resetting the totals or leaving them as they were, for an instance.



3.5. Checking the LCD

All the icons of the LCD can be checked by pressing and holding the **RIGHT** button during turning the power supply on or after exiting the last menu. Releasing the button will allow the computer to go to normal mode.

3.6. Removing the power

Total A and total B are both stored in the non-volatile memory every 50 second.
Before removing the power make sure that there was no flow for the last minute.

4. MENU DIAGRAM

The menu diagram for GFC110A-B flow computer / totalizer is shown below.

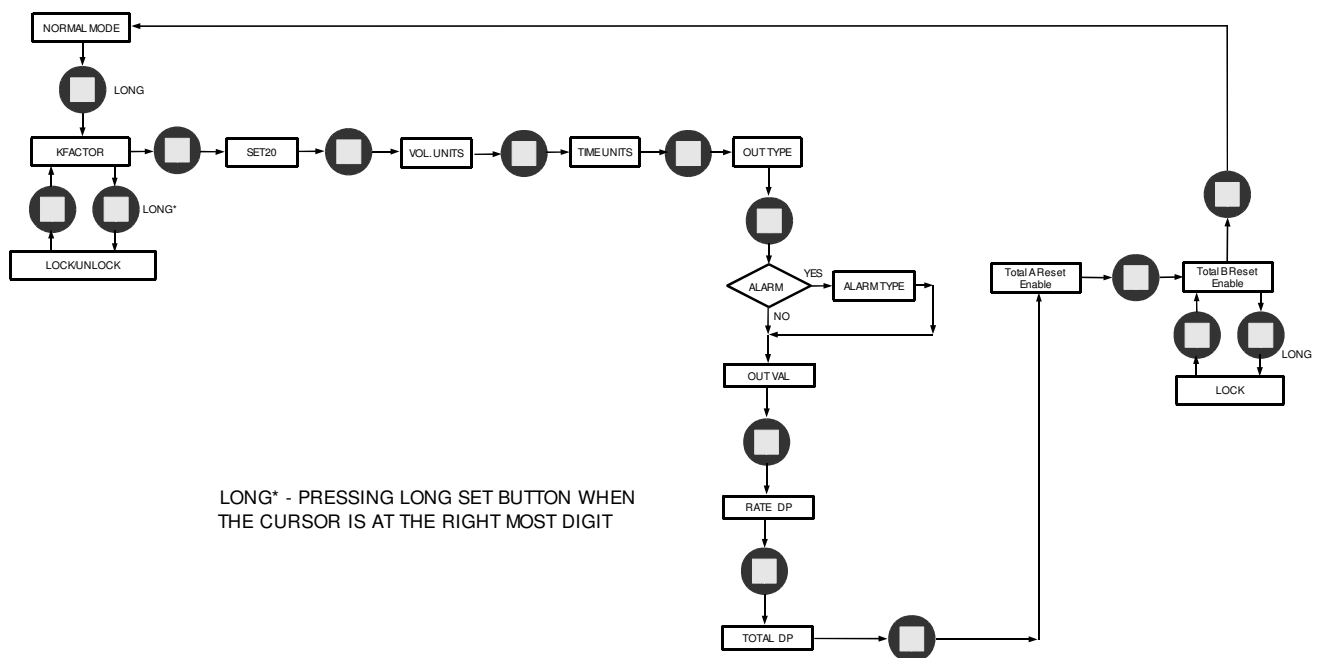

5. APPLICATION

5.1. ELECTRICAL

The wiring diagram is shown below.

NOTE: There is no isolation between the sensor input and the power supply. Terminals 2, 4 and 9 are shorted inside the device. It is the user's responsibility to consider this fact and implement appropriate wiring in the particular user's application.

- 1 – Power supply plus
- 2 – Power supply minus
- 3 – Pulse B. The sensor output must be sinking (open drain, open collector, reed switch etc.)
- 4 –
- 5, 6 – Digital output, no polarity
- 7 – Flow Sensor power, plus
- 8 – Pulse A. The sensor output must be sinking (open drain, open collector, reed switch etc.)
- 9 – Flow Sensor power, minus.
- 10 – Analog output plus
- 11 – Analog output minus

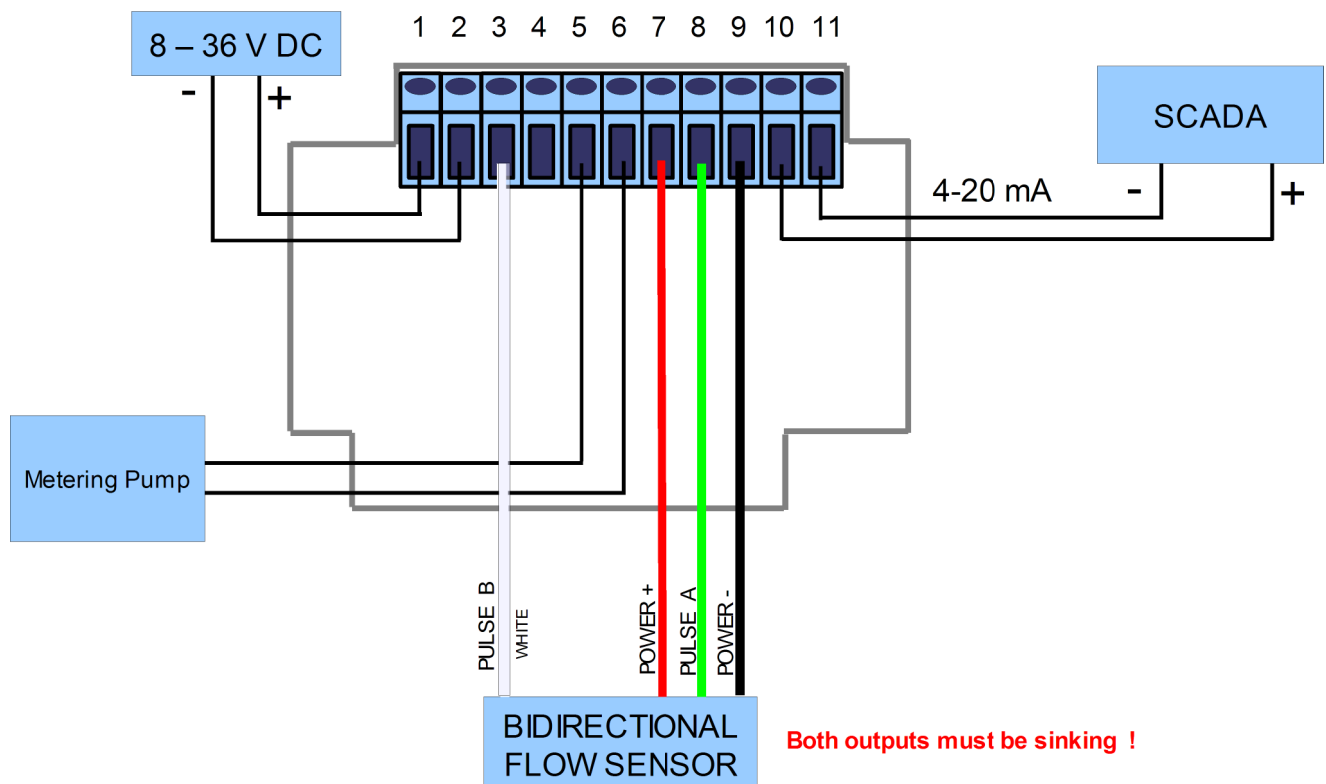

5.2. MECHANICAL

Mounting GFC110A-B on a wall requires an area of 120 x 65 mm (4.73 x 2.56 inch) and two screws:

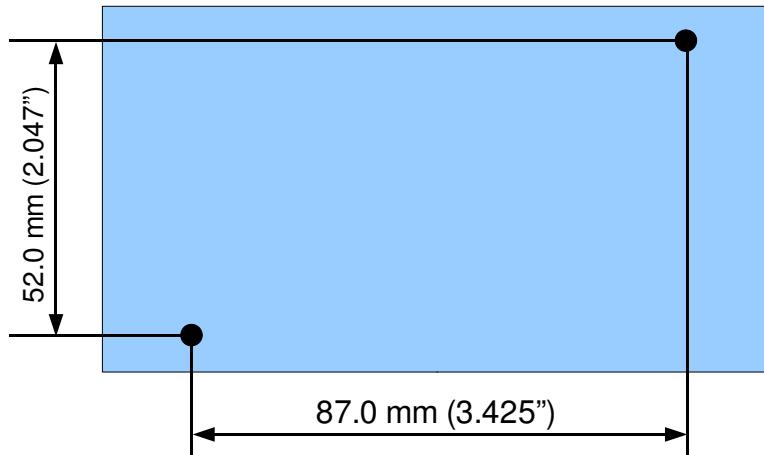

NOTE: The cable grips and the cables need additional space

6. ORDERING

For ordering please use the following G Instruments part numbers:

Description	G Instruments PN
GFC110A-B flow computer without power supply (external 8 – 36 V DC required)	30350
GFC110A-B flow computer with GPS115 (115 VAC power supply)	30351
GFC110A-B flow computer with GPS220 (220 VAC power supply)	30352
GFC110A-B flow computer with GPS122 (85-264 VAC power supply)	30353



IMPORTANT NOTICE

G Instruments reserves the right to make corrections, modifications, enhancements, improvements, and other changes to its products at any time without notice.

Customers should obtain the latest relevant information before placing orders and should verify that such information is current and complete.

G Instruments does not assume any liability arising from the use of any device or circuit described herein, nor does it convey any license under its patent rights or the rights of others.

Customers are responsible for their products and applications using G Instruments devices. To minimize the risks associated with customer products and applications, customers should provide adequate design and operating safeguards.

G Instruments products are not authorized for use as critical components in life support devices or systems without express written approval of G Instruments.

Trademarks and registered trademarks are the property of their respective owners.